

# EUROLIFT®

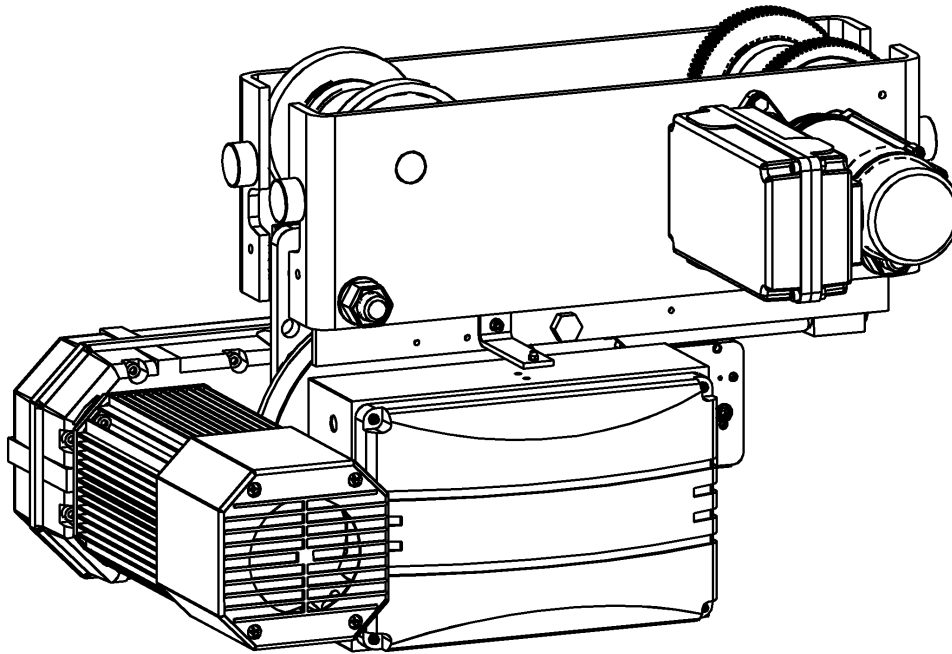

## **GUIDE**

---

## **TECHNIQUE**

---

## ***TECHNICAL GUIDE***

**PALAN ELECTRIQUE A SANGLE TYPE EUROLIFT BH**  
***ELECTRIC BELT HOIST TYPE EUROLIFT BH***

 **VERLINDE**<sup>®</sup>  
LIFTING EQUIPMENT

### SOMMAIRE

Description	p 2
Caractéristiques générales	p 3
Moteur et réducteurs de levage	p 4
Sangle	p 6
Mouflages	p 7
Vitesse de levage	p 8
Limiteur de charge	p 9
Fins de course de levage	p 12
Version anti corrosion	p 13
Charges maxi. aux galets	p 14
Codification du palan	p 15

### INDEX

<i>Description</i>
<i>Main specifications</i>
<i>Hoisting motor and gears</i>
<i>Belt</i>
<i>Reeving</i>
<i>Lifting speed</i>
<i>Overload device</i>
<i>Hoisting limit switches</i>
<i>Anti corrosion version</i>
<i>Max. wheel load</i>
<i>Hoist codification</i>

## DESCRIPTION

## DESCRIPTION

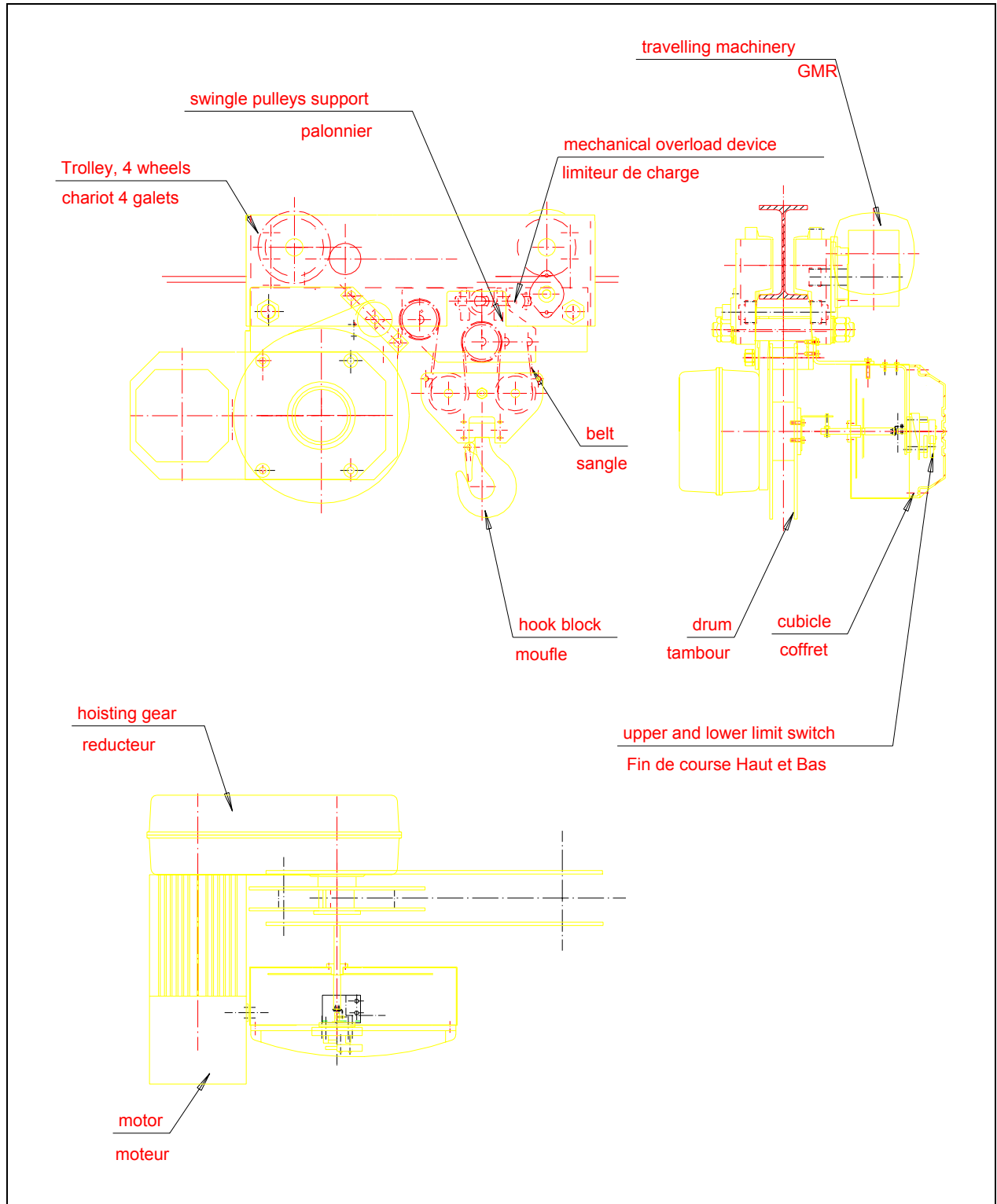

### Caractéristiques générales

1 ) Charge, Hauteur de Levage,  
Vitesse de Levage

### Main specifications

1 ) Load, Height of Lift, Hoisting  
Speed

Charge (kg) / groupe FEM Load (kg) / FEM group			Hauteur de levée (m)	Type de palan	Nombre de brins	Vitesse maxi de levage m/mn
1 Bm	1 Am	2 m	<i>Height of lift</i>	<i>hoist type</i>	<i>number of falls</i>	<i>hoisting speed</i>
500	-	-	9	BH202R3	2	20/3.3
-	-	500	6	BH203R5	3	13.3/2.2
-	630	-	6	BH203R4	3	13.3/2.2
800	-	-	6	BH203R3	3	13.3/2.2
-	-	630	9	BH202L5	2	10/1.6
-	800	-	9	BH202L4	2	10/1.6
1000	-	-	9	BH202L3	2	10/1.6
-	-	1000	6	BH203L5	3	6.6/1.1
-	1250	-	6	BH203L4	3	6.6/1.1
1600	-	-	6	BH203L3	3	6.6/1.1
-	-	1250	4.5	BH204L5	4	5/0.8
-	1600	-	4.5	BH204L4	4	5/0.8
2000	-	-	4.5	BH204L3	4	5/0.8

### 2 ) PARTICULARITES :

- levage centré
- hauteur perdue réduite
- vitesse de levage variable
- Pour toute application en environnement agressif (poussières...)
- Moufle isolée électriquement du palan
- Tirage en biais admissible

### 2 ) PARTICULARITIES :

- True vertical lift
- Low headroom
- Variable hoisting speed
- For aggressive environment (dust...)
- Isolated hook block
- side lifting possible

## Moteur, Frein et Réducteurs de levage

## Hoisting Motor, Brake and Gears

### 1 ) MOTEUR DE LEVAGE

Moteur Type : N1

- moteur asynchrone
- à double enroulement
- protection IP 55
- isolation classe F
- avec sondes de détection de surchauffe
- carcasse en aluminium

### 1 ) HOISTING MOTOR

Motor Type : N1

- asynchronous motor
- double winding
- IP 55 protection
- class F insulation
- with thermistors for over temperature protection
- aluminium frame

Moteur (50 Hz)	Vitesse de rotation	Puissance nominal	Temps de fonct. cont.	Couple de démarrage	Couple Nominal	Couple de freinage
<i>Motor (50 Hz)</i>	<i>Synchr. speed (rpm)</i>	<i>Nominal power</i>	<i>Short time duty</i>	<i>Starting torque</i>	<i>Nominal torque</i>	<i>Braking torque</i>
type	tr/mn	kW	mn	Nm	Nm	Nm
N1	3000/500	1.9/0.3	15/15	12/10.7	6.3	10.8

### 2 ) FREIN DE LEVAGE

Frein électromagnétique à manque de courant, avec réglage automatique

### 2 ) HOISTING BRAKE

*Electromagnetic brake, self adjusting*

### 3 ) REDUCTEUR DE LEVAGE

Carter étanche, graissé à vie, denture hélicoïdale traitée et rectifiée

Deux type : - lent ( L ) rapport 1/129  
- rapide ( R ) rapport 1/61

### 3 ) HOISTING GEARS

*Totally enclosed, life lubricated,  
helical gear treated and rectified*

Two type : - slow ( L ) ratio 1/129  
- fast ( R ) ratio 1/61

**ATTENTION :** Retirer l'évent du réducteur de levage avant l'utilisation du palan

**ATTENTION :** Remove the breather of the hoisting gearbox before using the hoist

### 3) Description moteur de levage

### 3) Hoisting motor description

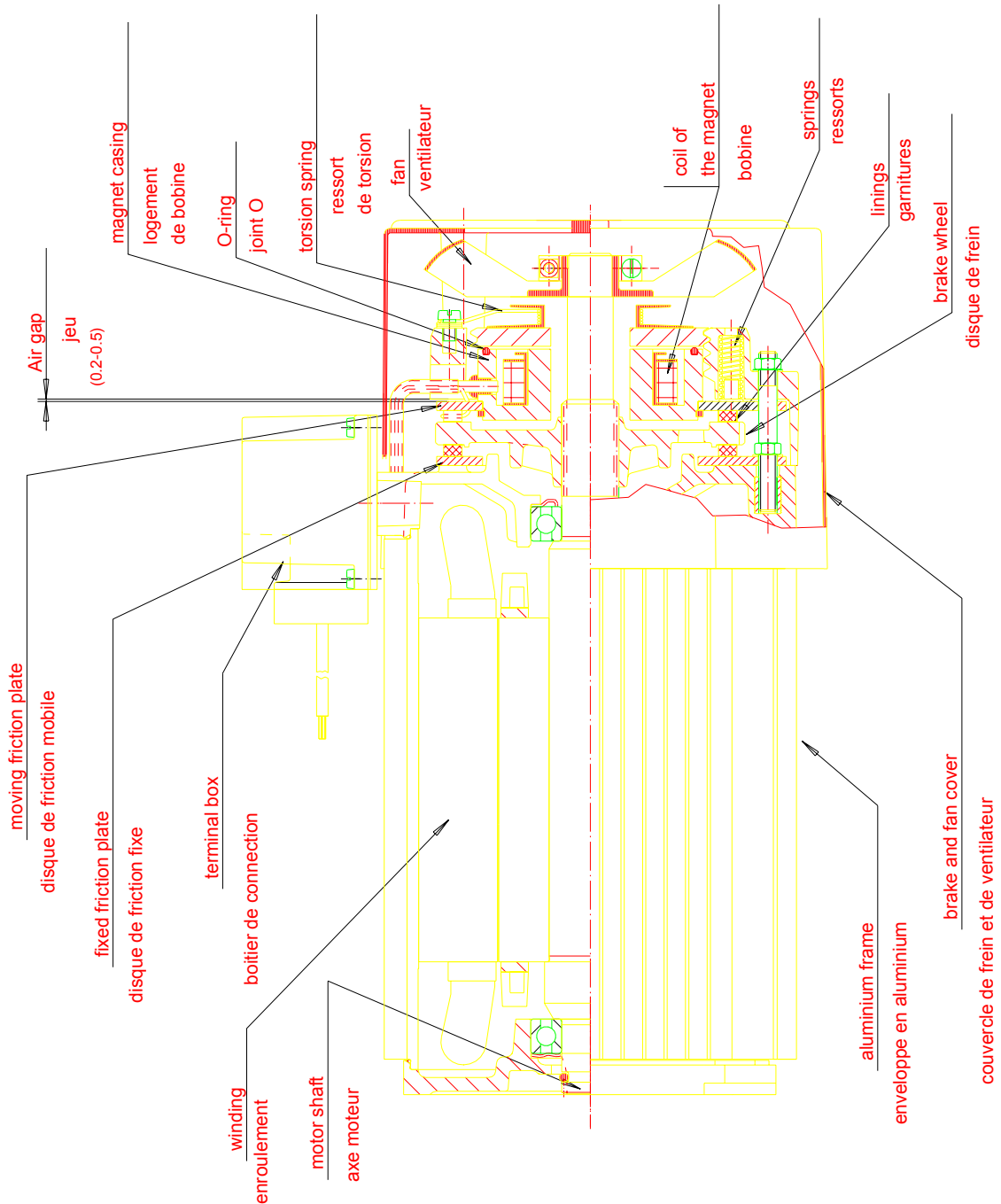

### Sangle de levage

**Matière :** 100% POLYESTER

**Largeur :** 36 mm  $\pm$  1 mm

**Force de rupture R :** > 4500 daN

**Coefficient de sécurité :** 8.4

**Ratio épaisseur sangle diamètre poulie :** 20

**Epaisseur :** 3.3 mm  $\pm$  0.2 mm

**Allongement :** 7 %  $\pm$  2 sous 1/3de R

**Combustion :** Fond à 260 °C

**Toxicité :** Aucune

**Putrescibilité :** imputrescible

**Tenue à la lumière :** bonne

**Tenue à l'abrasion :** bonne

**Poids au mètre :** 78 grs  $\pm$  5

**Divers :**

- Bon isolant électrique
- Bonne ténacité résiduelle après passage dans l'eau bouillante

### Lifting belt

**Material :** 100% POLYESTER

**Width :** 36 mm  $\pm$  1 mm

**Breaking load R :** > 4500 daN

**Safety factor :** 8.4

**Belt thickness, pulley diameter ratio :** 20

**Thickness :** 3.3 mm  $\pm$  0.2 mm

**Elongation :** 7 %  $\pm$  2 under 1/3 R

**Combustibility :** melt at 260 °C

**Toxicity :** None

**Putricibility :** unputrescible

**Resistance to light :** satisfactory

**Resistance to abrasion :** satisfactory

**Weight per meter :** 78 grs  $\pm$  5

**Other:**

- Good electrical insulating material
- Good residual strength after being put in boiling water (73%)

### MOUFLAGES

### REEVING

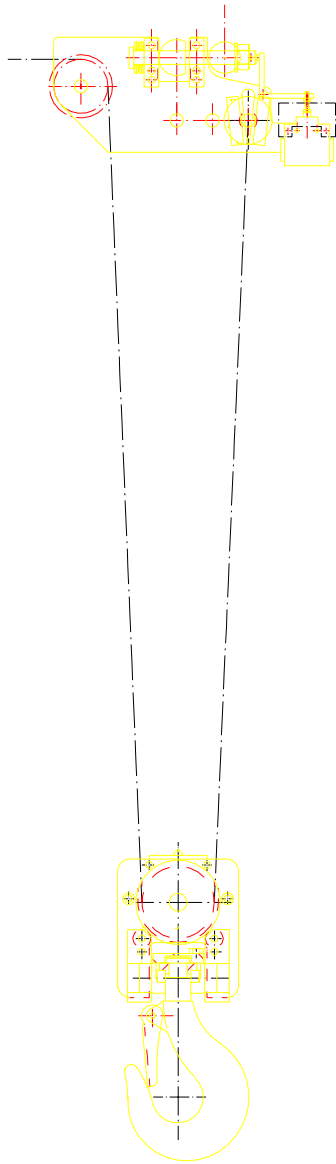

2/1

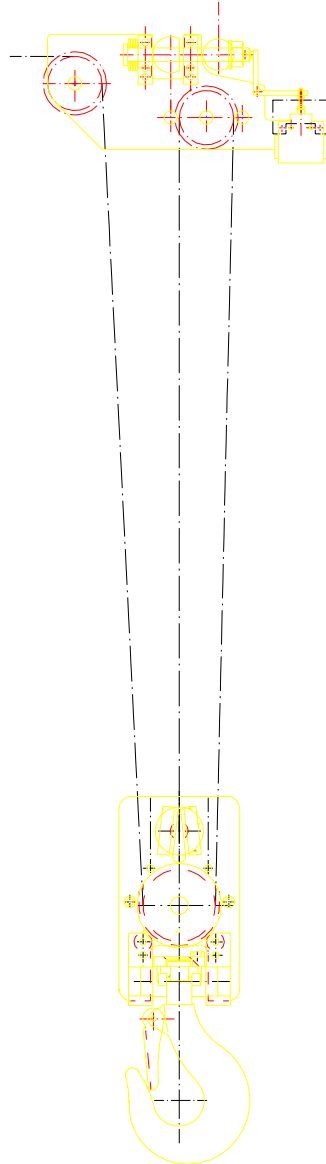

3/1

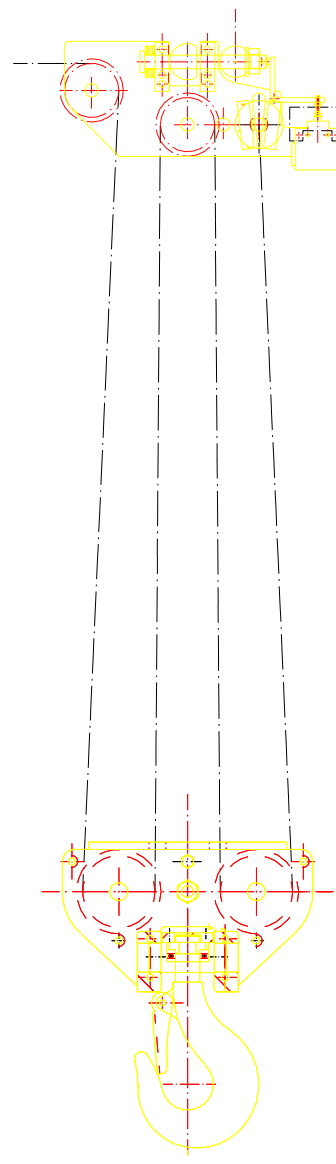

4/1



## VITESSES DE LEVAGE

## LIFTING SPEED

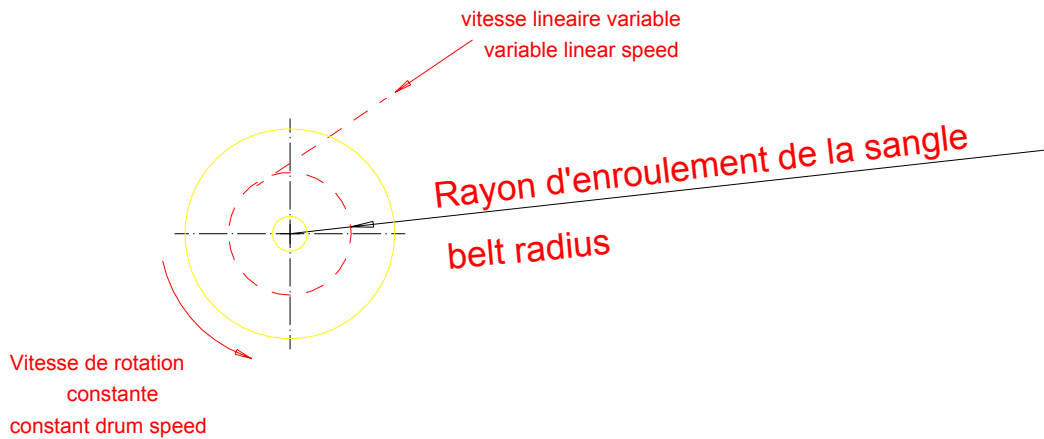

Vitesse de levee = vitesse de rotation axe tambour x Rayon d enroulement de la sangle  
Lifting speed = drum speed x belt radius

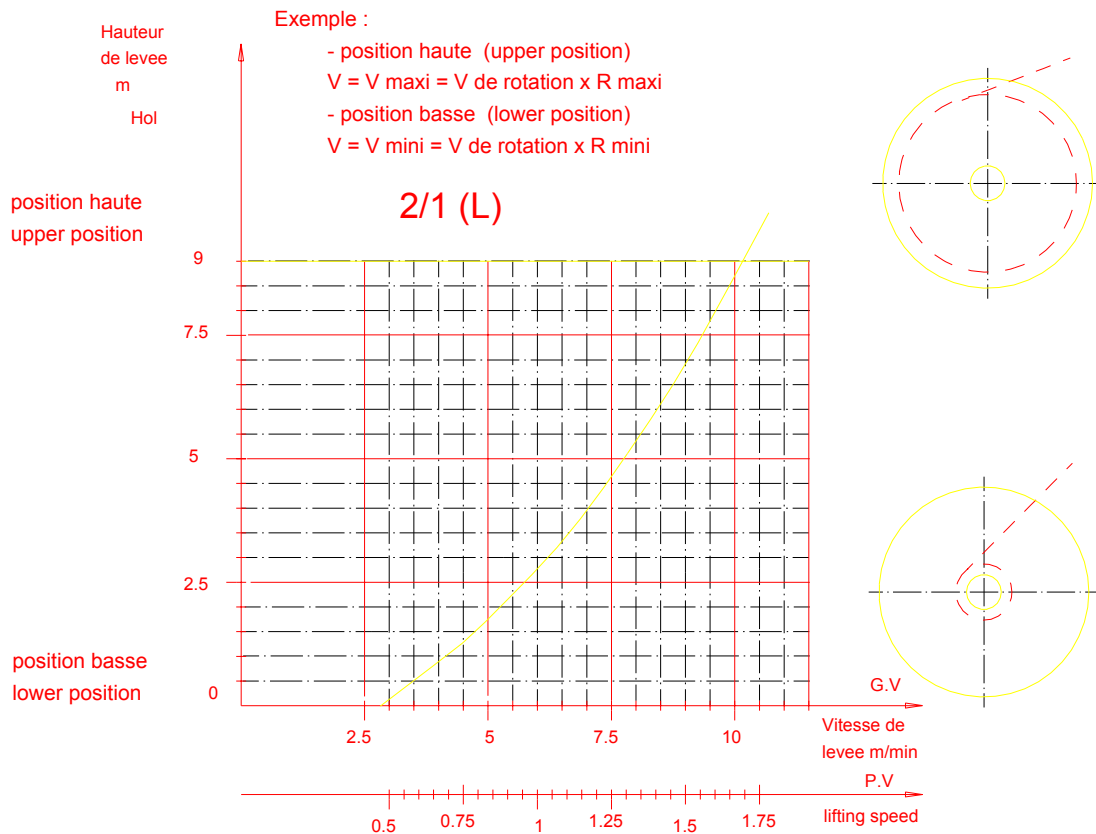

## VITESSES DE LEVAGE

## LIFTING SPEED

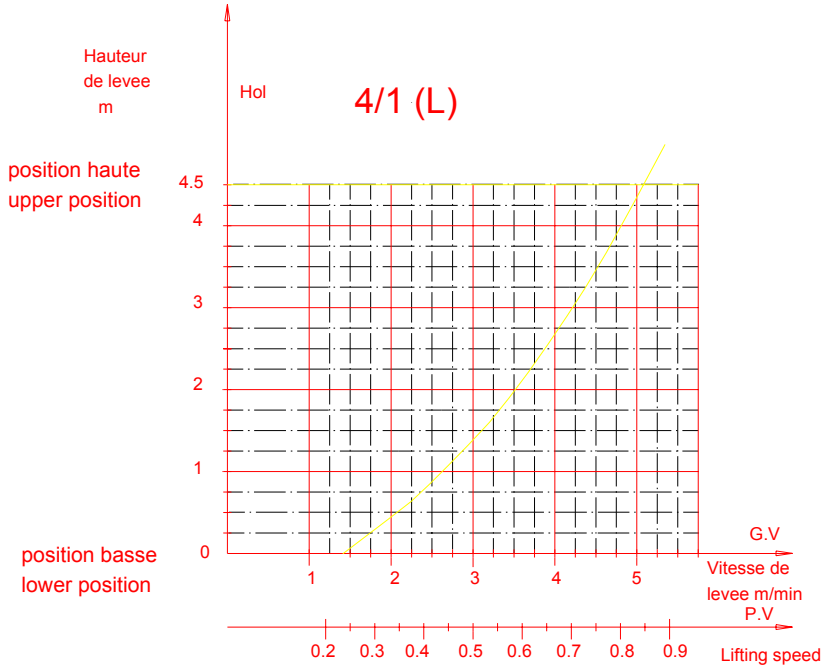
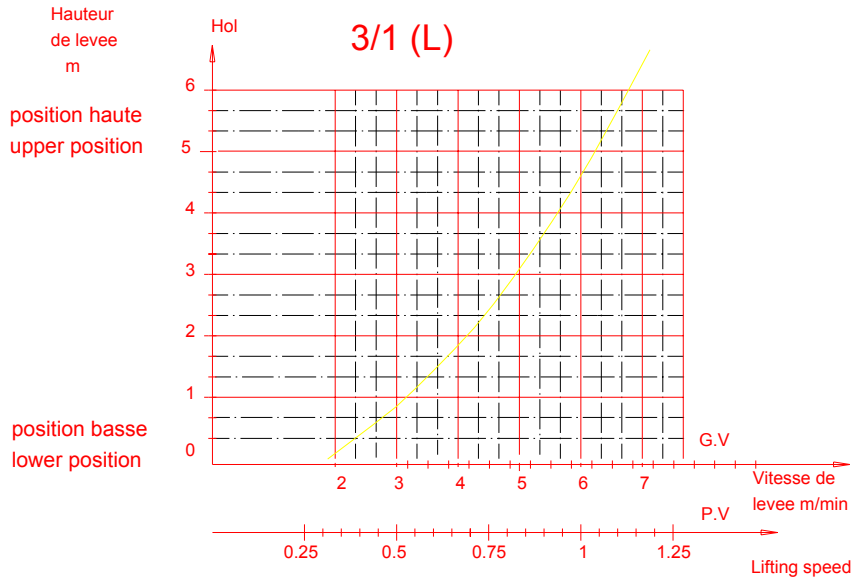

## VITESSES DE LEVAGE

## LIFTING SPEED

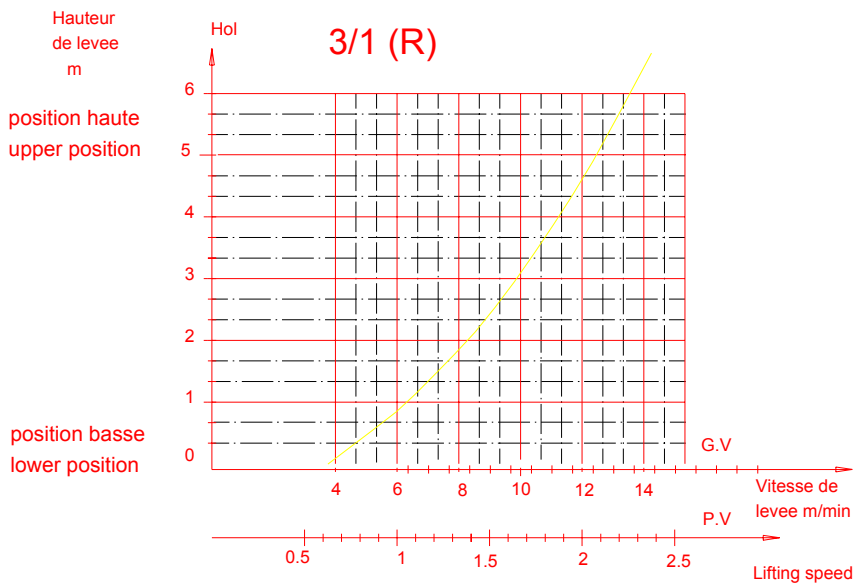
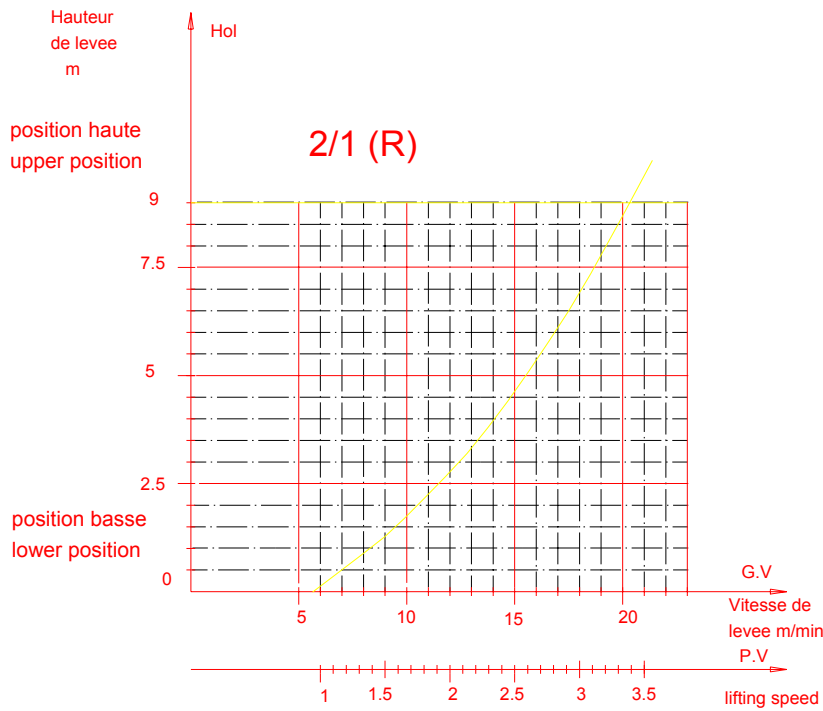

### LIMITEUR DE CHARGE

### OVERLOAD LIMITOR

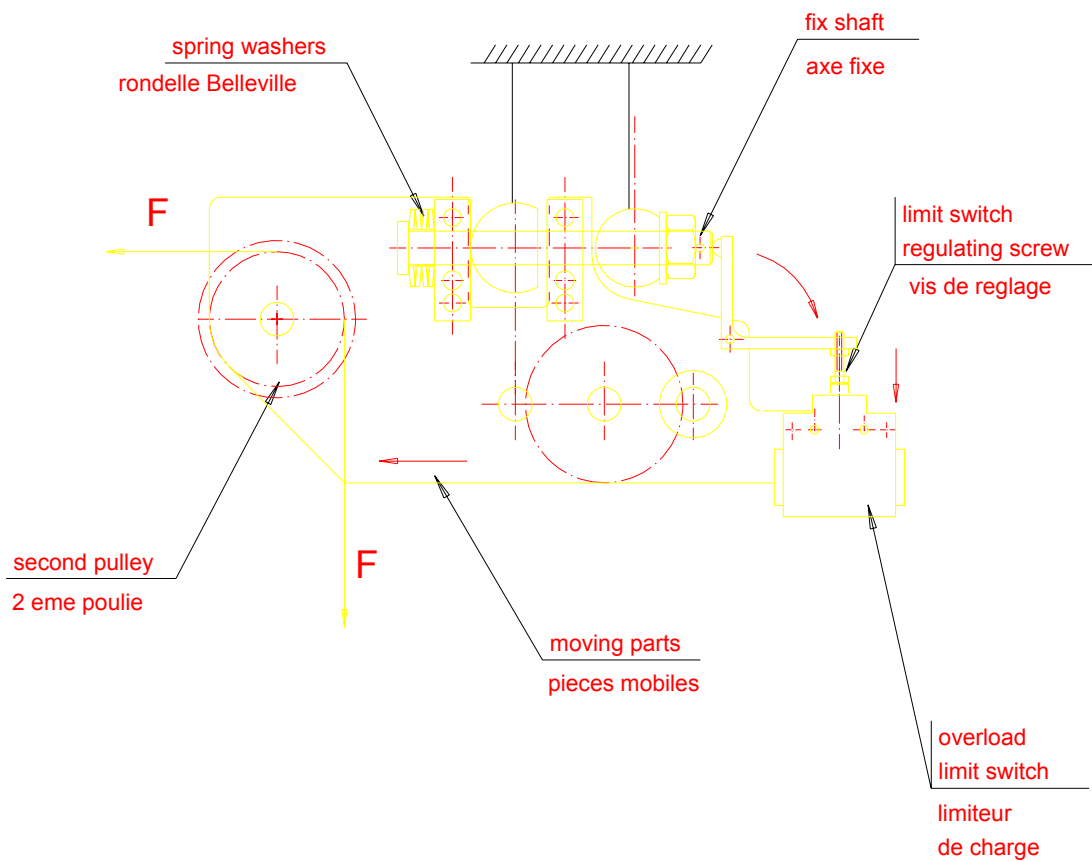

## Fin de course de levage

## Hoisting limit switches

### 1 ) STANDARD

### 1 ) STANDARD

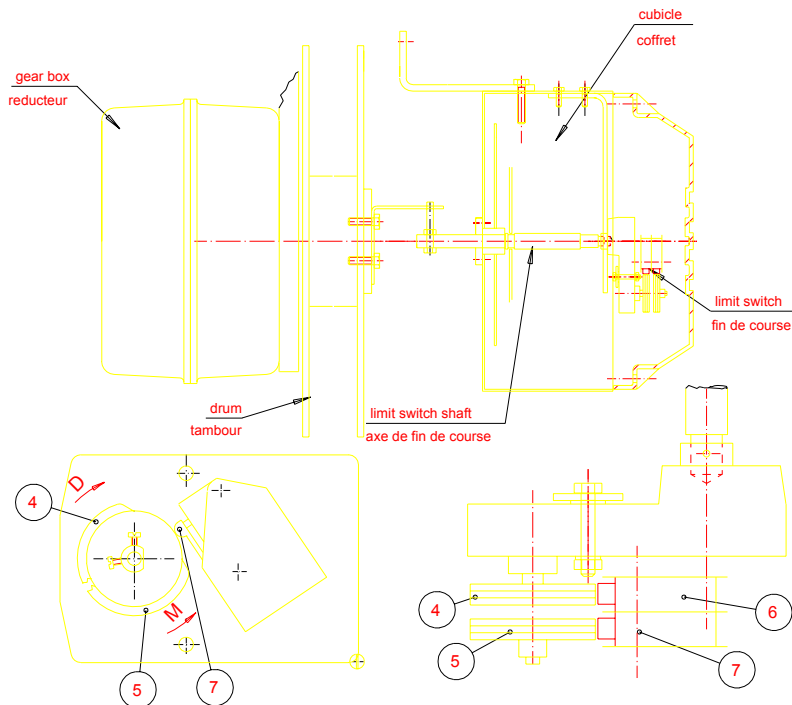

- 4 Came de commande fin de course bas  
Lower limit switch cam
- 5 Came de commande fin de course haut  
Upper limit switch cam
- 6 Interrupteur de fin de course bas  
Lower limit switch
- 7 Interrupteur de fin de course haut  
Upper limit switch

### 2 ) OPTIONS

Sur-course haut actionné par la moufle

### 2 ) OPTIONS

Hook operated upper limit switch

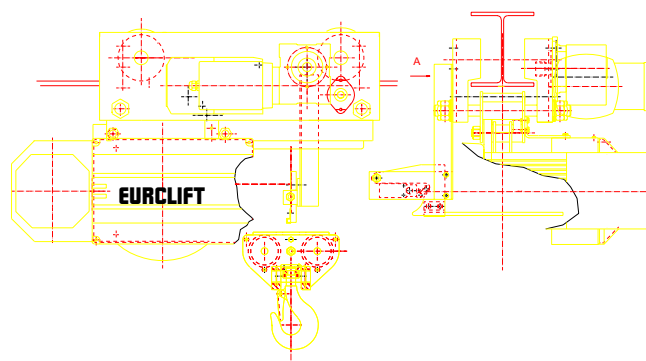

## Version anti-corrosion

### 1 ) DESCRIPTION

- Moufle : crochet, chape, roulement et corps sont en acier inoxydable.
- Tambour : les flasques tambour, support de tambour sont zingués à chaud.
- Chariot : Les flasques de chariot, de palonnier, et d'ossature sont zingués à chaud, les galets, axes de transmission, entretoises, pièces du palonnier sont électrozingués bichromatés.

### 2 ) APPLICATIONS

- Pour toute application en environnement agressif (vapeur, eau salée...)
- Industries alimentaires, pharmaceutiques...

## Anti corrosion version

### 1 ) DESCRIPTION

- *Hook block : hook, lower cross-head and lower pulley block are stainless steel.*
- *Drum : The belt drum and its fixing are hot dipped galvanized.*
- *Trolley : The side plates of the trolley are hot dipped galvanized, wheels, axles, power transmission system and diverter sheaves are electro galvanized.*

### 2 ) APPLICATIONS

- *For aggressive environment (vapour, salt water...)*
- *Food, pharmaceutical industries for example)*

### Charges maximum aux galets

### Maximum wheels load

#### 1 ) Charges

#### 1 ) Load

Charge (kg) / Load (kg)		Mouflage / Reeving		
		2/1	3/1	4/1
FEM	1 Bm	800	1250	2000
	1 Am	630	1000	1600
	2 m	500	800	1250

#### 2 ) Charges maximum (dynamique + statique)

#### 2 ) Maximum load

Charge (kg) / Load (kg)		Mouflage / Reeving		
		2/1	3/1	4/1
FEM	1 Bm	1150	1709	2641
	1 Am	965	1437	2203
	2 m	821	1214	1804

#### 3 ) Charges dynamique maximum sur un galet porteur

#### 3 ) Maximum dynamic ungeared wheel load

Charge (kg) / Load (kg)		Mouflage / Reeving		
		2/1	3/1	4/1
FEM	1 Bm	134	199	307
	1 Am	112	167	256
	2 m	95	141	210

#### 4 ) Charges dynamique maximum sur un galet moteur

#### 4 ) Maximum dynamic geared wheel load

Charge (kg) / Load (kg)		Mouflage / Reeving		
		2/1	3/1	4/1
FEM	1 Bm	441	656	1013
	1 Am	370	552	845
	2 m	315	466	692

### Codification du Palan

### Hoist Codification

BH	PALAN A SANGLE TYPE BH / HOIST TYPE BH									
	2	TAILLE / FRAME SIZE 2								
		02	MOUFLAGE / REEVING 02, 03, 04							
			L	REDUCTEUR DE LEVAGE / HOISTING GEAR BOX L = Lent / Slow R = Rapide / Fast						
				3	GROUPE / GROUP 3 = 1Bm 4 = 1Am 5 = 2m 6 = 3m					
					E	CHARIOT TYPE / TROLLEY TYPE N = HPN / Normal headroom trolley B = Chariot boggies / Boggey trolley E = Chariot EUROSISTEM / EUROSISTEM trolley S = Fixe suspendu / Fix suspended (no trolley)				
<b>BH</b>	<b>2</b>	<b>02</b>	<b>L</b>	<b>3</b>	<b>B</b>	<b>20</b>	<b>A</b>	<b>405</b>	<b>S</b>	<b>40</b>
<b>LARGEUR DE VOIE / FLANGE WIDTH</b>						<b>20</b>				
09 = 66 – 90 mm			20 = 186 – 200 mm							
11 = 91 – 110 mm			22 = 201 – 220 mm							
16 = 111 – 160 mm			24 = 221 – 240 mm							
18 = 161 – 180 mm			30 = 241 – 300 mm							
19 = 181 – 185 mm			00 = Chariot S & E S & E Trolley typ							
<b>VERSION / VERSION</b>							<b>A</b>			
S = Standard										
M = Standard avec moufle inox / Standard with stainless steel hook block										
A = Anti-corrosion / Total stainless steel protection										
<b>TENSION / POWER SUPPLY</b>								<b>405</b>		
235 = 230 V / 50 Hz										
405 = 400 V / 50 hz										
446 = 440 V / 60 Hz										
415 = 415 V / 60 Hz										
<b>EQUIPEMENT ELECTRIQUE / ELECTRICAL EQUIPMENT</b>									<b>S</b>	
S = Palan solo / Solo										
K = Palan pour kit / Kit										
O = Sans / No										
<b>VITESSE DE DIRECTION / TRAVELLING SPEED</b>										
40 = 40 & 10 m / min										
30 = 30 & 7.5 m / min										
20 = 20 & 5 m / min										
10 = 10 & 2.5 m / min										
00 = Pas de chariot / No trolley										



